

TERMOMETRO DIGITALE

Montaggio Radiale

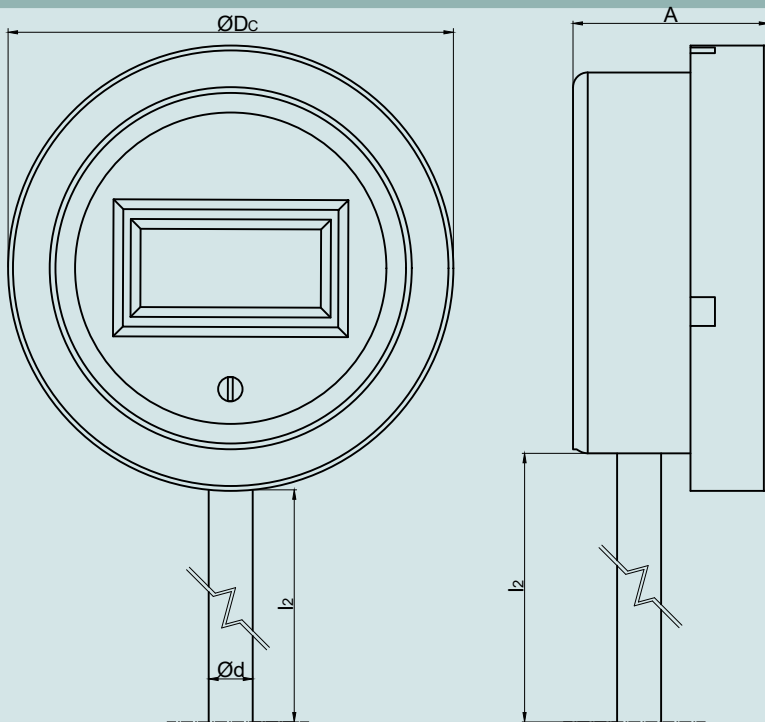

Montaggio Posteriore

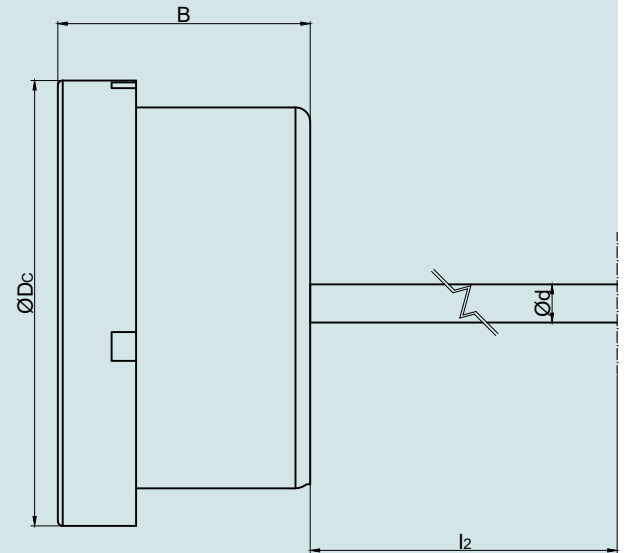

Montaggio Orientabile

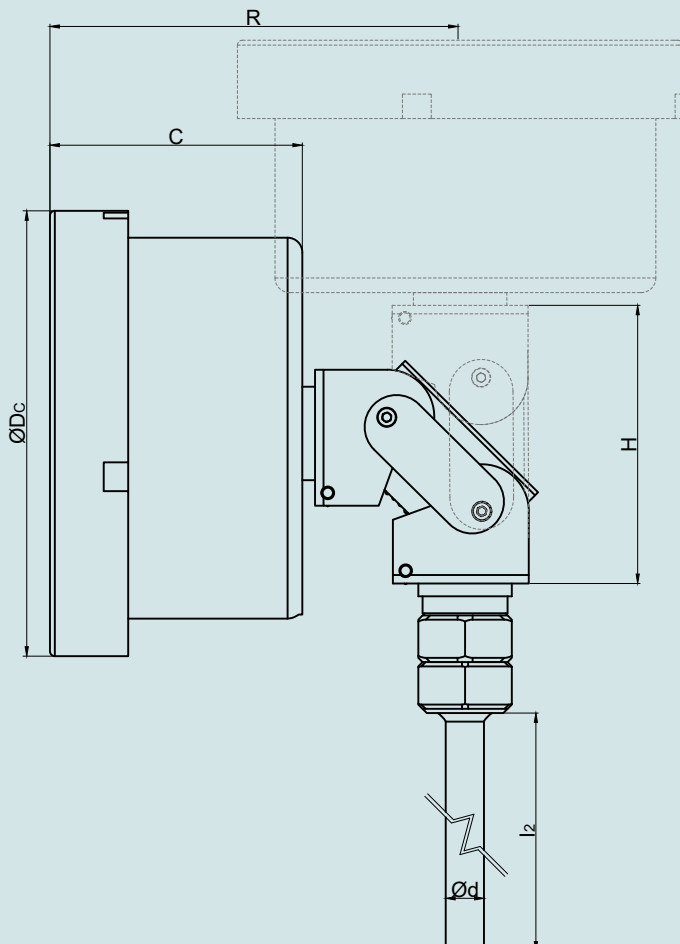

Tipo	Dimensioni in mm					
	ØD _c	A	B	C	R	H
Radiale	80	40	-	-	-	-
Posteriore	80	-	45	-	-	-
Orientabile	80	-	-	45	55	60

ØD_c Diametro cassa

A Spessore Cassa Term. Radiale

B Spessore Cassa Term. Posteriore

C Spessore Cassa Term. Orientabile

H Ingombro Raccordo orientabile = 60 mm

R Distanza tra cassa e centro di rotazione

l₂ Lunghezza gambo termometro

Ød Diametro gambo termometro = 9 mm